



ETS-EVO

Disciplined RF Generator

Rev 1.6

Dichiarazione di conformità Declaration of conformity	
La Ditta <i>The Company</i>	DIGITAL INSTRUMENTS S.r.l. Via Parco degli Scout, 13 20091 BRESSO (MI) ITALY
Dichiaro con la presente che il Prodotto <i>Herewith declares that the Product</i>	
Tipo / <i>Type</i>	Disciplined RF Generator
Modello / <i>Model</i>	ETS-EVO
Serial Number	0130 /
Oggetto di questa dichiarazione è conforme ai seguenti standard o norme della Comunità Europea <i>Referred to by this declaration is in conformity with the following standards or normative documents of EC</i>	
Norme Europee Armonizzate <i>European Armonized Standards</i>	
CEI EN 61000-6-4:2007	Electromagnetic compatibility (EMC) - Part 6-4: Generic standards - Emission standard for industrial environments
CEI EN 61000-6-2:2006	Electromagnetic compatibility (EMC) - Part 6-2: Generic standards - Immunity for industrial environments
CEI EN 55011:2011	Limits and methods of measurement of radio disturbance characteristics of industrial, scientific and medical (ISM) radio-frequency equipment
CEI EN 61000-4-2:2011	Electromagnetic compatibility (EMC) - Part 4-2: Testing and measurement techniques - Electrostatic discharge immunity test
CEI EN 61000-4-3:2007+A1:2009+A2:2011	Electromagnetic compatibility (EMC) - Part 4-3: Testing and measurement techniques - Radiated, radio-frequency, electromagnetic field immunity test
CEI EN 61000-4-4:2006+A1:2010	Electromagnetic compatibility (EMC) - Part 4-4: Testing and measurement techniques - Electrical fast transient/burst immunity test
CEI EN 61000-4-5:2007	Electromagnetic compatibility (EMC) - Part 4-5: Testing and measurement techniques - Surge immunity test
CEI EN 61000-4-6:2011	Electromagnetic compatibility (EMC) - Part 4-6: Testing and measurement techniques - Immunity to conducted disturbances, induced by radio-frequency fields
CEI EN 61000-4-8:1997+A1:2001	Electromagnetic compatibility (EMC) - Part 4-8: Testing and measurement techniques - Power frequency magnetic field immunity test
CEI EN 61000-4-11:2010	Electromagnetic compatibility (EMC) - Part 4-11: Testing and measurement techniques - Voltage dips, short interruptions and voltage variations immunity tests
CEI EN 60204-1:2006+A1:2010	Safety of machinery - Electrical equipment of machines - Part 1: General requirements
Bresso, December 2011	DIGITAL INSTRUMENTS S.r.l. Via Parco degli Scout, 13 20091 BRESSO (MI) ITALY <i>Marco Genova</i> <i>Quality Assurance Manager</i>

Istruzioni di sicurezza Safety Instructions

Il dispositivo è stato progettato, costruito e collaudato in conformità alle normative richiamate nel Certificato di Conformità ed è stato rilasciato dal costruttore completamente testato secondo gli standard di sicurezza. Per mantenere questa condizione e assicurare la sicurezza d'uso, l'utente deve osservare tutte le istruzioni e segnalazioni di pericolo descritte in questo manuale.

This unit has been designed and tested in accordance with the EC Certificate of Conformity and has left the manufacturer's plant in a condition fully complying with safety standard. To maintain this condition and to ensure safe operation, the user must observe all the instructions and warnings given in this operating manual.

- **Prima di mettere in servizio il dispositivo, leggere attentamente ed integralmente le istruzioni per l'uso. Osservarle e seguirle in tutti i punti. Provvedere in modo che le istruzioni per l'uso siano sempre accessibili a tutti gli addetti.**

Prior to switching on the unit, please read carefully the instructions on the manual. Keep this manual available for all every user of this equipment.

- **Il terminale PE sul dispositivo deve essere connesso al conduttore PE prima di eseguire qualsiasi altra connessione. L'installazione ed il cablaggio devono essere eseguiti da personale tecnico qualificato.**

The PE terminal of the unit must first be connected to the PE conductor on site before any other connections are made. Installation and cabling of the unit to be performed only by qualified technical personnel.

- **Lo strumento supporta alimentazione AC wide range da 95 Vac a 240 Vac e deve essere connesso tramite protezione con corrente nominale massima pari a 16A.**

This unit may be operate from wide range AC supply networks from 95 Vac to 240 Vac fused with max. 16A.

- **Lo strumento supporta alimentazione DC wide range da 20 Vdc a 50 Vdc e deve essere connesso tramite protezione con corrente nominale massima pari a 5A. Il circuito di protezione contro l'inversione di polarità è implementato a bordo.**

This unit may be operate from wide range DC supply networks from 20 Vdc to 50Vdc fused with max. 5A. Circuit against polarity inversion is also implemented.

Le condizioni di sicurezza vanno testate ad ogni sostituzione. Ispezione visiva dei cavi, stato dell'isolamento, corrente di dispersione, stato del connettore PE e test funzionale.

A safety test must be performed after each replacement of part. Visual inspections, PE conductor test, insulation resistance, leakage-current measurement, functional test.

- **Non interrompere il conduttore PE in nessun caso. Un'interruzione del cavo PE rende l'apparato elettricamente pericoloso.**

It is not permissible to interrupt PE conductor intentionally, neither in the incoming cable nor on the unit itself as this may cause the unit become electrically hazardous.

- **Ogni riparazione, manutenzione e sostituzione del dispositivo deve essere eseguita unicamente da personale autorizzato dalla Digital Instruments.**

Any adjustments, replacements of parts, maintenance or repair may be carried out only by authorized Digital Instruments technical personnel.





- **Assicurarsi che ogni collegamento con dispositivi informatici sia eseguito secondo IEC950/EN60950**

Ensure that the connections with information technology equipment comply with IEC950/EN60950

Simboli di sicurezza Safety Symbols

Sono presenti sul dispositivo e nella documentazione simboli utilizzati per la segnalazione di segnalazione conformi alle specifiche IEC61010-1 II.

Safety-related symbols used on equipment and documentation comply with IEC 61010-1 II.

	<ul style="list-style-type: none"> • SIMBOLO DIRECT CURRENT IEC 417, N°5031 Vdc may be used on rating labels
	<ul style="list-style-type: none"> • SIMBOLO ALTERNATING CURRENT IEC 417, N°5032 For rating labels, the symbol is typically replaced by V and Hz as in 230V, 50Hz.
	<ul style="list-style-type: none"> • SIMBOLO PROTECTIVE CONDUCTOR TERMINAL IEC 417, N°5019 This symbol is specifically reserved for the PROTECTIVE CONDUCTOR TERMINAL and no other. It is placed at the equipment earthing point and is mandatory for all grounded equipment
	<ul style="list-style-type: none"> • SIMBOLO CAUTION ISO 3864, N°B.3.1 used to direct the user to the instruction manual where it is necessary to follow certain specified instructions where safety is involved.

Changelog

Rev.	Note	Data
1.0	First review	14/11/2011
1.1	Added notes on the software update and the discovery of the IP address	17/11/2011
1.2	Updated CE certification and notes on the use of the serial protocols	07/02/2012
1.3	Added FAQ and Changelog Appendix	16/05/2012
1.4	Added ABB SPA Time protocol	27/06/2012
1.5	Added NMEA Time protocol	09/07/2012
1.6	Added section about Custom Settings	30/10/2012

ETS-EVO

Multi-Sources Disciplined RF Generator

Table of Contents

Summary	6
Front View	7
Rear View	7
Connectors details	8
Main Operation	9
GPS.....	9
NTP.....	9
PTP (IEEE 1588).....	10
IRIG-B.....	11
Date and time	12
Switchover Function	13
Switchover threshold	13
WEB interface	14
Serial Protocols.....	18
Event Log	20
SNMP Trap Management	21
User Account	21
Custom Settings	22
Board Bring-Up	23
Appendix A: Quality Factor	24
General Review	24
GPS antenna positioning.....	24
Quality Factor	25
Statistics.....	26
Automatic Site Survey	26
Appendix B: FAQ	27
Appendix C: Changelog	28
Assistance	30
Technical Data	31

Summary

This manual provides to the user of the apparatus **ETS-EVO** all the information necessary for proper operation. The informations include the normal installation procedures and any data on the maintenance and programming in order to facilitate interventions in the field.

ETS-EVO is a very flexible solution to generate high-stability Time (PPS, IRIG code, NTP/PTP) and Frequency (10 MHz) reference signals.

ETS-EVO accepts inputs from a GPS radio or via the NTP/PTP protocol.

ETS-EVO is able to generate programmable pulses and has event time function through dry contact.

ETS-EVO also features an integrated full-featured PTP and NTP server to provide date and time synchronization to PCs over network.

ETS-EVO is provided with a double RJ-45 10/100 Fast Ethernet jack. The apparatus can be set as PTPv2 Grandmaster clock. If GPS antenna is not present, the unit become NTP/Stratum 2 or PTP/Slave.

ETS-EVO can be managed via web through a very intuitive interface or via the well-known SNMP protocol.

Multiple sources can be used as backup to provide a redundant mean of synchronization. Automatic switchover based on customizable priorities is implemented, without any noticeable interruption in the outputted time-frequency signals.

ETS-EVO has double Power Supply Unit, to ensure best safety and uninterrupted work.

ETS-EVO is in metallic box of sizes 1U 19'' for rack installation.

Note

This document may contain confidential and or reserved material of property of Digital Instruments S.r.l. It cannot be reproduced, used or shown to third parties for any other scope than the intended one.



WARNING: Before inserting the power supply please carefully read all instructions for proper installation.

Front View

The front panel appears as in the following figure.
At the center is a row of status LEDs.

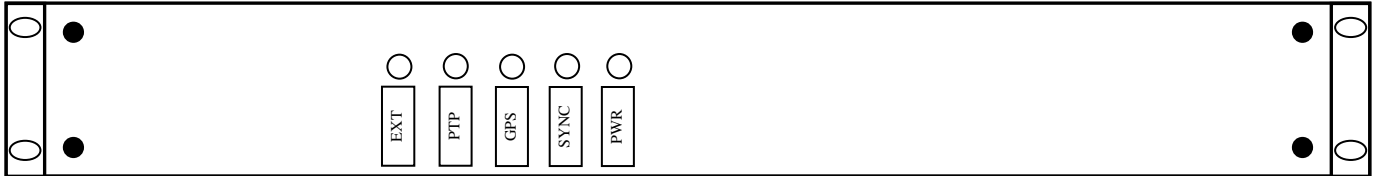

Rear View

The figure below shows the back of the *ETS-EVO* with the positions of the connectors and their electrical wiring.

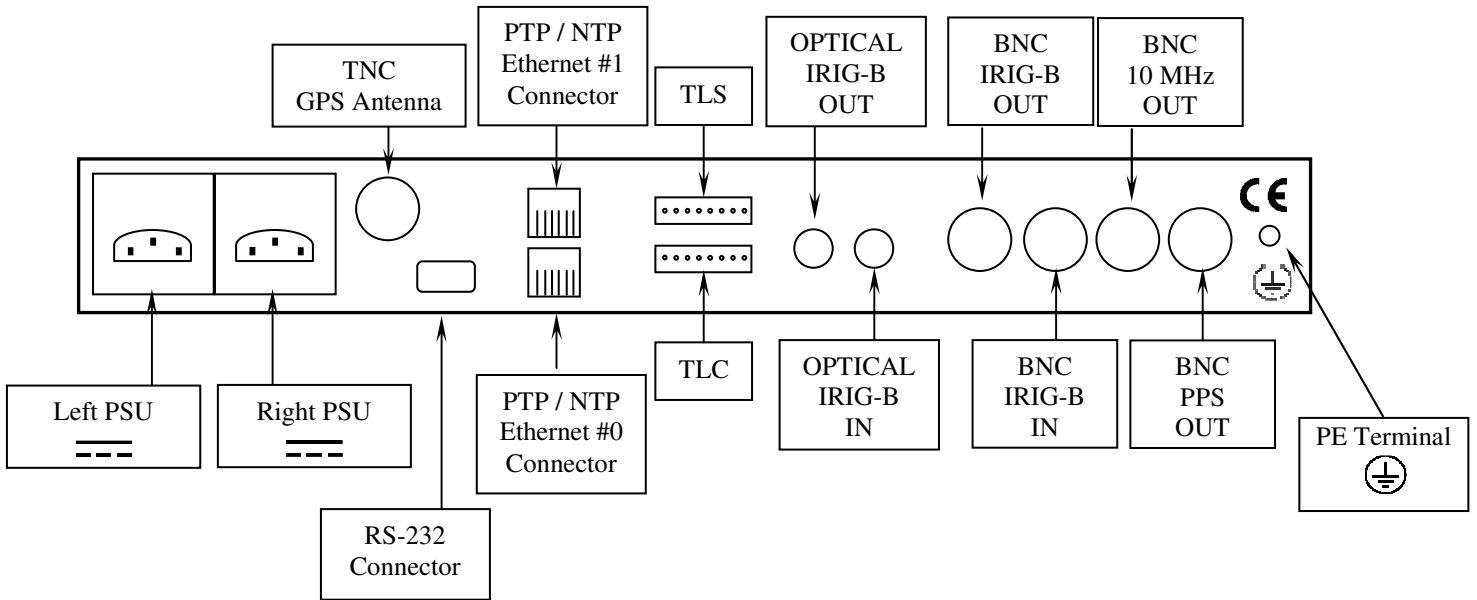

ETS-EVO does not provide any supply switch.

Connectors details

TLS connector (Remote signals)



The 8 poles TLS connector provides the following information on the various pins (from left to right):

- PIN 1: Common contact
- PIN 2: Closed contact → Right power supply provided
- PIN 3: Closed contact → Left power supply provided
- PIN 4: Closed contact → GPS reference present and valid
- PIN 5: Closed contact → PTP reference present and valid
- PIN 6: Closed contact → IRIG-B reference present and valid
- PIN 7: Closed contact → NTP protocol working
- PIN 8: Closed contact → Synchronization completed

TLC connector (Remote controls)

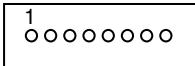

The 8 poles TLC connector provides the following commands on the various pins (from left to right):

- PIN 1-2: Powered contact → Manual switch
- PIN 3-4: Powered contact → Automatic switch
- PIN 5-6: Powered contact → Switch over next reference
- PIN 7-8: Powered contact → Switch over previous reference

Main Operation

The main purpose of the *ETS-EVO* is to provide stable output signals of Time (PPS, IRIG code, NTP/PTP) and Frequency (10 MHz), and to enable the synchronization of the network.

This is allowed by the application of algorithms, tuning an high-stability internal oscillator.

Peculiarities of the *ETS-EVO* is the possibility to accept input from four different sources:

1. GPS
2. NTP
3. PTP (IEEE 1588)
4. IRIG-B

In this manner it is possible to switch from one source to another, if a fault occurs.

The strong difference between the various sources is a major strength as it makes the same apparatus both very flexible to suit the needs of the customer and very strong in order to better cope with possible failures of a type of source (for example, the loss of accuracy of the GPS signal).

Even in case of a switch, references of Time / Frequency provided are kept stables.

GPS

The apparatus is internally equipped with a GPS receiver especially suitable for use as a time reference. The GPS receiver is able to reproduce the local PPS signal relative to UTC second with a precision of typically ± 100 ns. With this feature is possible to regulate the internal oscillator apparatus for producing a high-stability output signal of 10 MHz and PPS.

NTP

The NTP (Network Time Protocol) is a well-established standard for synchronization of PCs and other devices on the Internet or an Intranet network.

The accuracy of the order of tens of milliseconds, can be considered adequate for most situations. Its flexibility and strength, thanks to the many servers widely available, making it a very smart choice for time synchronization.

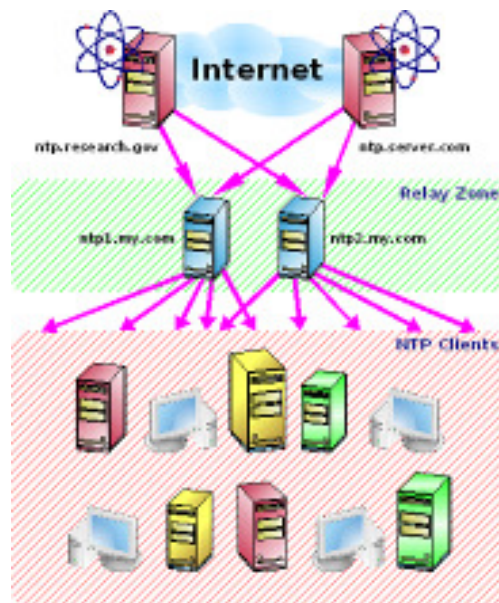

PTP (IEEE 1588)

The *ETS-EVO* supports the IEEE 1588-2008 (version 2), also known as *Precision Time Protocol*, both as master and slave. When connected to an appropriate device compatible to the IEEE 1588 standard is able to synchronize the slave apparatus with a precision well below the micro-second.

Note that using network switches non-compliant with IEEE 1588, variable delays in the order of some tens of microseconds are introduced (as noted in the official website of the Protocol <http://ieee1588.nist.gov/switch.htm>).

The IEEE 1588 bases its operation on the calculation of the transit time of PTP packets from the master to the slave (and slave to master).

These latencies are calculated using a simple exchange of messages between master and slave that are associated with timestamps managed at the hardware level.

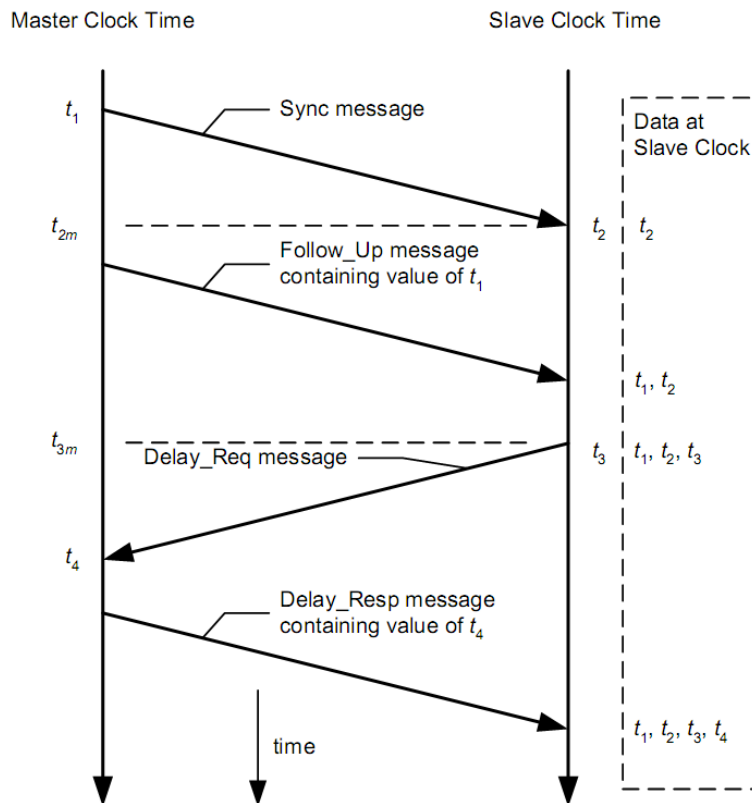

Once reconstructed the one-way-delay it is possible to use it to correct the clock of the slave and lock it to the master. Below is shown the pattern of the loop relative to the clock tuning based on PTP.

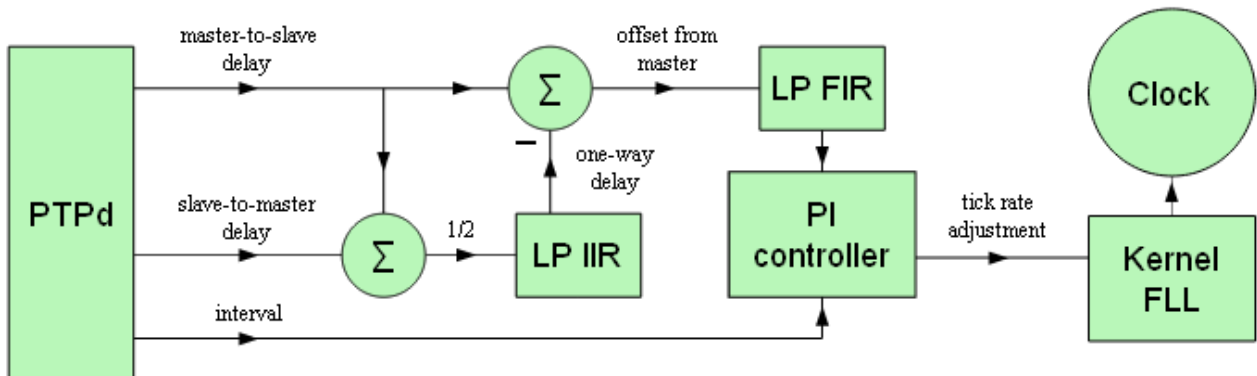

IRIG-B

The device can accept in input and provide in output (on BNC and optical connectors) an IRIG-B stream of type 006, compliant with following code:

Bit position	Information transmitted
0	Position identifier P_R (seconds' boundary marker)
1–4	Units of seconds
6–8	Tens of seconds
9	Position identifier P_1
10–13	Units of minutes
15–17	Tens of minutes
19	Position identifier P_2
20–23	Units of hours
25–26	Tens of hours
29	Position identifier P_3
30–33	Units of days
35–38	Tens of days
39	Position identifier P_4
40–41	Hundreds of days
49	Position identifier P_5
50–53	Units of year or control function bits
55–58	Tens of year or control function bits
59	Position identifier P_6
60–68	Control function bits
69	Position identifier P_7
70–78	Control function bits
79	Position identifier P_8
80–88	Nine lowest significant bits of time of day in straight binary seconds (bit 80 $\rightarrow 2^0$... bit 88 $\rightarrow 2^8$)
89	Position Identifier P_9
90–97	Eight most significant bits of time of day in straight binary seconds (bit 90 $\rightarrow 2^9$... bit 97 $\rightarrow 2^{16}$)
99	Position identifier P_0
Note: Bits not listed are index markers, and are sent as binary zeroes.	

It was also implemented part of the standard 1344-1995. The offset compared to the UTC time can be set using the Timezone of the apparatus. Changes of DST or leap second are not currently notified (always returned as 0).

IRIG-B Pos ID	CTRLB IT#	Designation	Explanation
P50	1	Year, BCD 1	Last 2 digits of year in BCD
P51	2	Year, BCD 2	IBID
P52	3	Year, BCD 4	IBID
P53	4	Year, BCD 8	IBID
P54	5	Not used	Unassigned
P55	6	Year, BCD 10	Last 2 digits of year in BCD
P56	7	Year, BCD 20	IBID
P57	8	Year, BCD 40	IBID
P58	9	Year, BCD 80	IBID
P59	-	P6	Position identifier # 6
P 60	10	Leap second pending (LSP)	Becomes 1 up to 59 s BEFORE leap second insert
P 61	11	Leap second (LS)	0 = Add leap second, 1 = Delete leap second
P62	12	Daylight saving pending (DSP)	Becomes 1 up to 59 s BEFORE DST change
P63	13	Daylight savings time (DST)	Becomes 1 during DST
P 64	14	Time offset sign	Time offset sign – 0=+, 1=-
P65	15	Time offset-binary 1	Offset from coded IRIG-B time to UTC time IRIG coded time plus time offset (including sign) equals UTC time at all times (offset will change during daylight savings)
P 66	16	Time offset-binary 2	
P 67	17	Time offset-binary 4	
P68	18	Time offset-binary 8	
P 69	-	P7	Position identifier # 7
P70	19	Time offset-0.5 hour	0 = none, 1 = additional 0.5 h time offset
P71	20	Time quality	4 b code representing approx. clock time error 0000 = clock locked, maximum accuracy 1111 = clock failed, data unreliable.
P72	21	Time quality	
P73	22	Time quality	
P74	23	Time quality	
P75	24	PARITY	Parity on all preceding data bits
P76	25	Not used	Unassigned
P77	26	Not used	Unassigned
P78	27	Not used	Unassigned
P79	-	P8	Position identifier # 8

Date and time

The device disciplines its internal clock from the selected reference (GPS, PTP, IRIG-B, NTP) and distributes it with the following rules:

- NTP (UTC time as per standard)
- PTP (UTC time)
- IRIG-B (localtime configured by user with the Timezone setting)

Switchover Function

ETS-EVO allows the possibility to switch the disciplining of its internal timebase selecting one of many sources. This exchange can be configured to run automatically upon occurrence of an alarm condition, such as:

- PPS signal absence
- disconnection of the antenna
- error in the external source
- error in the PTP protocol

In the log are reported the reason of the switch:

Mweb	→ user defined switch from web
Msnmp	→ user defined switch from SNMP
Aser	→ automatic switch due to serial connection lack of GPS
Aant	→ automatic switch due to connection lack of GPS antenna
Apref	→ automatic switch to the higher priority source
Aptp	→ automatic switch caused by errors in the PTP protocol

Switchover threshold

This variable allows to define a time interval (in seconds) that must elapse between the time when an error has been identified and when it will be exchanged effectively. If during this time the error will disappear, the exchange will be deleted.

WEB interface

The *ETS-EVO* is managed by the network using a common browser by simply connecting to the IP address associated with it.

Main panel

From the main panel, the user can view the status of the source, indicating the distance (time delay) of the Time signal from Time signal reconstructed by the specific source.

Clicking on the source, the user can select it to the internal oscillator tuning, if the exchange is set on *Manual*.



From the tabs on the left side it's possible to retrieve the status of each source.



The position of the satellites can be seen by clicking on Polar view.



Network Configuration Panel

Board ID

Allows to define a name to the apparatus, useful for identifying it on the network

Trap Dest

Allows to configure the destination server of the traps related to the events.

IP

Allows to set up the IP address associated to the the specific network interface. To activate the changes, system needs to restart.

Netmask

Allows to set the netmask associated to specific network interface. To activate the changes, system needs to restart.

Gateway

Allows to set the gateway associated with specific network interface. To activate the changes, system needs to restart.

Reset to default

Restores the original configuration

Reboot the board

Restarts the device

Date & Time

Allows to view/set the date and time of the apparatus. Note that this will still be automatically updated to that received by satellite.

Timezone

Allows to set the UTC offset for proper time visualization.

This setting determines the IRIG-B time offset.

Guest Account Settings

Allows to change the credentials of the user account (see below for more details)

Admin Account Settings

Allows to change the credentials for the administrator account (see below for more details)

Sources Config Panel

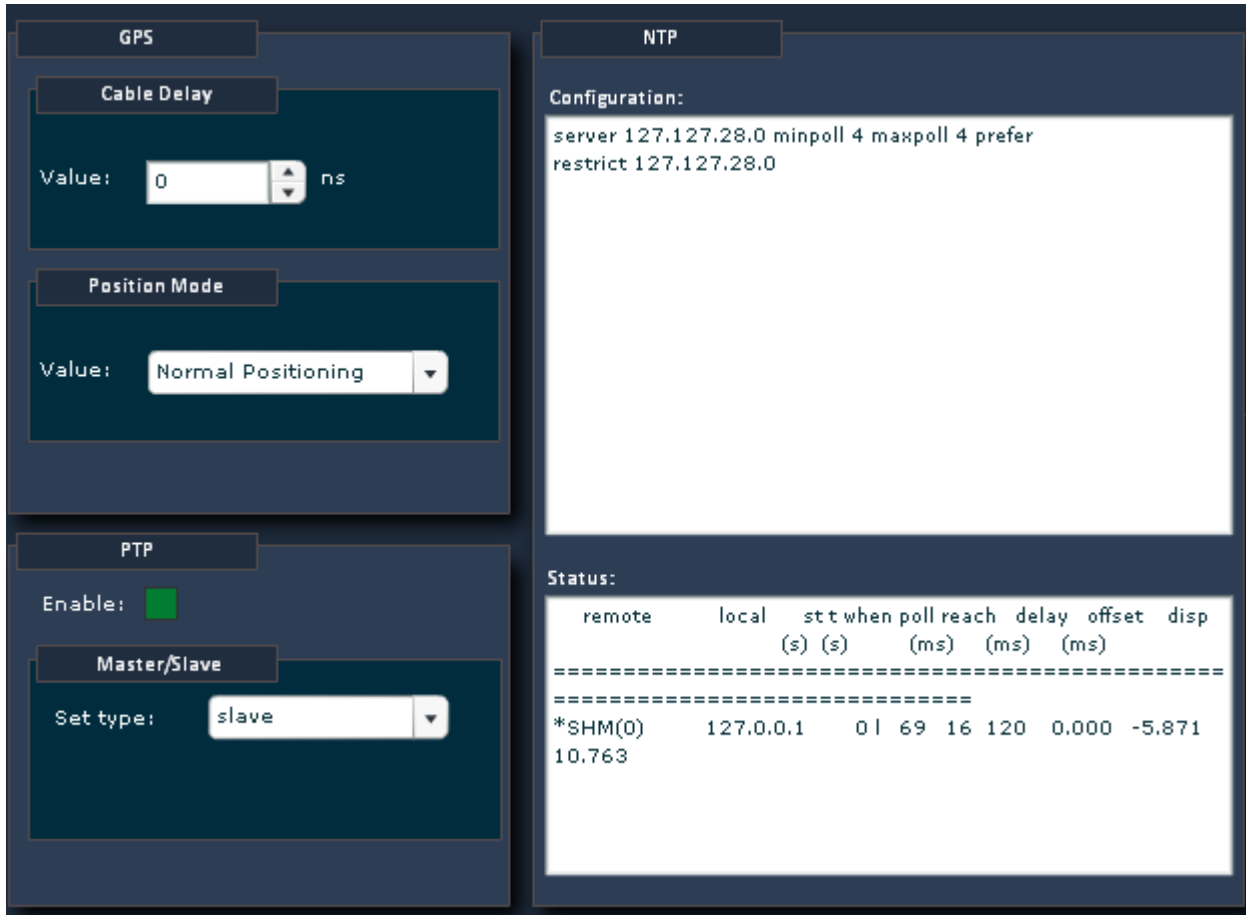

GPS

Cable Delay

Allows the setting of the length of the cable that separates the GPS antenna from the apparatus, so as to compensate the signal propagation delays.

Positioning Mode

Allows to set the calculating mode of the geographic coordinates done by GPS receiver. If derived from information provided by satellites or maintain the one set by the user. The mode "Altitude Hold" may not be available on all versions of the GPS radio.

PTP

Enable

Allows to switch on or off the PTP.

Type

Allows to choose to configure the device as a Grandmaster or a Slave.

NTP

Configuration

Allows to change the configuration of the NTP (please refer to the NTPd¹ syntax)

Status

Allows to obtain information about the status of NTP

¹ <http://www.eecis.udel.edu/~mills/ntp/html/confopt.html#server>

Board Config Panel



Switch Mode

Allows to set the type of switching (manual or automatic)

Switch-over

Allows to modify the switch-over time

PPS Mux

Allows to choose which signal spread on the PPS connector on the back

IRIG-B In

Allows to configure from which connector to retrieve the IRIG-B input

Serial Protocol

Allows to configure the behaviour of the serial port (for more details please refer to section *Serial Protocols*)

Priority

Set the priority of each source for the automatic switch (a higher value means a higher priority, 0 disables the source)

Firmware Update

Allows to load a file for an eventual firmware upgrade

Serial Protocols

The ETS-EVO has a serial RS-232 interface on the back that can be used as a serial console or configured to output a serial protocol.

The PC must be provided with a serial connector DB9M (9 pins).
The signals on each pin are shown in the following table:

Pin	Signal	I/O	Signal description
1	DCD	I	Data Carrier Detect (optional)
2	RxD	I	Received Data
3	TxD	O	Transmitted Data
4	DTR	O	Data Terminal Ready
5	GND	-	Signal Ground
6	DSR	I	Data Set Ready
7	RTS	O	Request to Send
8	CTS	I	Clear to Send
9	RI/+5...+15V	I/O	Ring Indicator (optional) or auxiliary supply voltage (optional)



A null-modem cable must be used, with the tx and rx lines switched (to let two DTE devices to talk). It may be that some USB → RS232 adapters would cause problems with the electrical criteria.

Serial Console

When configured as a serial console it is possible to login on the device with the serial configuration **115200/8-N-1** and typing **root** as login and **root** as password.

It is always possible to force the switch over the serial console by using a serial terminal able to control the serial criteria² and set **DTR = ON** e **RTS = OFF**.

Uni Erlangen

The Uni Erlangen format consists of 66 ASCII characters formatted in the following way:

<STX>dd.mm.yy; w; hh:mm:ss; +uu:uu; uvxyzab; ll.lllln lll.lllle hhhm<ETX>

<STX> = start-of-text, ASCII code 0x02
dd.mm.yy = day of month, month, year of the century, separated by dots
w = day of week (1..7, Monday = 1)
hh:mm:ss = hour, minute, second, separated by colons
+uu:uu = offset to UTC in hours and minutes, preceded by + or -
u = '#' if time is not synchronized, else ''
v = '*' if position has not been verified, else ''
x = 'S' if daylight saving time is active, else ''
y = '!' during the hour preceding start or end of daylight saving time, else ''
z = 'A' during the hour preceding a leap second, else ''
a = 'R' alternate antenna (reminiscent of PZF5xx), usually '' for GPS receivers
b = 'L' during a leap second, i.e. if the seconds field is 60, else ''
ll.lllln = position latitude in degrees, 'n' can actually be 'N' or 'S', i.e. North or South
lll.lllle = position longitude in degrees, 'e' can actually be 'E' or 'W', i.e. East or West
hhh = position altitude in meters, always followed by 'm'
<ETX> = end-of-text, ASCII code 0x03

The serial port must be configured for using the format **19200/8-E-1**.

² For example is possible to use the Bray Terminal program downloadable from the website <https://sites.google.com/site/terminalbpp/>

ABB SPA Time String

The ABB SPA Date and time string format consists of 32 characters formatted in the following way:

>900WD:yy-mm-dd hh.mm;ss.sss:cc<CR>

yy-mm-dd = year of the century , month and day of month, separated by dashes
 hh.mm = hours and minutes, separated by colons
 ss.sss = seconds and milliseconds, separated by colons
 cc = checksum (EXCLUSIVE-OR of the previous characters)

The serial port must be configured for using the format **9600/7-E-1**.

NMEA Time Strings

The following NMEA strings are being outputted on the serial port:

ZDA - Date and Time

\$GPZDA, hhmmss.ss, dd, mm, yyyy, xx, yy*CC
 \$GPZDA, 201530.00, 04, 07, 2002, 00, 00*60

hhmmss = HrMinSec(UTC)
 dd,mm,yyy = Day,Month,Year
 xx = local zone hours -13..13
 yy = local zone minutes 0..59
 *CC = checksum

GGA - essential fix data which provide 3D location and accuracy data.

\$GPGGA, 123519, 4807.038, N, 01131.000, E, 1, 08, 0.9, 545.4, M, 46.9, M, , *47

GGA = Global Positioning System Fix Data
 123519 = Fix taken at 12:35:19 UTC
 4807.038,N = Latitude 48 deg 07.038' N
 01131.000,E = Longitude 11 deg 31.000' E
 1 = Fix quality:
 0 = invalid
 1 = GPS fix (SPS)
 2 = DGPS fix
 3 = PPS fix
 4 = Real Time Kinematic
 5 = Float RTK
 6 = estimated (dead reckoning) (2.3 feature)
 7 = Manual input mode
 8 = Simulation mode
 08 = Number of satellites being tracked
 0.9 = Horizontal dilution of position
 545.4,M = Altitude, Meters, above mean sea level
 46.9,M = Height of geoid (mean sea level) above WGS84 ellipsoid
 (empty field) = time in seconds since last DGPS update
 (empty field) = DGPS station ID number
 *47 = the checksum data, always begins with *

The serial port must be configured for using the format **9600/8-N-1**.

Event Log

On the WEB is available the apparatus log from *Event log* section.
50 entries are presented.

It is possible to delete the logs and save them in *csv*. format.

Id	Date	Time	Code	Description
1	09/12/09	10:41:59	003	PPS Al. 1
2	09/12/09	10:41:59	003	PPS Al. 2
3	09/12/09	10:41:59	003	PPS Al. 3
4	09/12/09	10:41:59	003	PPS Al. 4
5	09/12/09	10:41:59	003	PPS Al. 5
6	09/12/09	10:41:59	003	PPS Al. 6
7	09/12/09	10:50:51	011	PPS Syncr
8				
9				
10				
11				
12				
13				
14				
15				
16				
17				
18				
19				

Events related to the board

Event Code 001	Power ON	→ Apparatus on
Event Code 002	Switch	→ Switching on GPS / EXT / E1 source
Event Code 003	PPS alarm	→ Alarm on PPS (1÷4)
Event Code 004	Clock alarm	→ Alarm on 10 MHz (1÷4) signal
Event Code 005	GPS Serial	→ Detection or loss of connectivity of the GPS radio
Event Code 006	Supply	→ Insertion or removal of a power supply (L, R)
Event Code 007	Switch Alarm	→ More than 3 exchanges in less than 5 minutes
Event Code 008	GPS PPS	→ Status change of PPS from satellite
Event Code 009	GPS Antenna	→ GPS antenna connection or disconnection
Event Code 010	Bad Vtune	→ Vtune incorrect value
Event Code 011	PPS Syncr	→ Synchronization completed
Event Code 018	PTP PPS	→ Change in the status of the PPS rebuilt by PTP

SNMP Trap Management

For each event related to the board, is generated a trap in parallel parallel to the machine set under TrapDest. The trap number reflects the event number and the contents of the SNMP variable associated contains the details (for example, the channel referred to the event).

User Account

The main user who has access to the apparatus is the administrator. He is able to change its credentials under *Account Settings*.

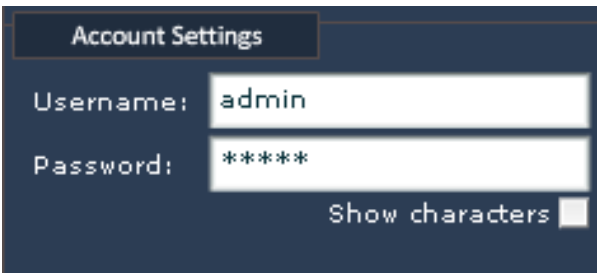

It's possible set a user account that is able to use the apparatus remotely in read-only mode, without the possibility of changing its configuration.

The username and password for this *guest* account can be set by the administrator under *Guest Account Settings*.

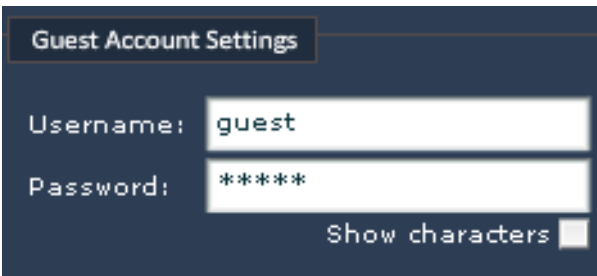

The default credentials are:

admin → **admin / admin**
guest → **guest / guest**

About SNMP:

Read community string → **public**
Write community string → **public**

Custom Settings

The device permits to have some ad-hoc customizations through the unlock with particular activation codes.

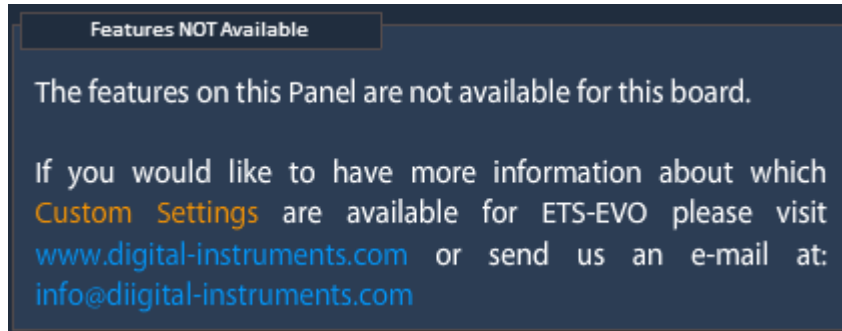

Pulse Generation

The device is able to generate a programmable pulse in place of the IRIG-B DCLS signal (on the BNC connector) or the PPS signal.

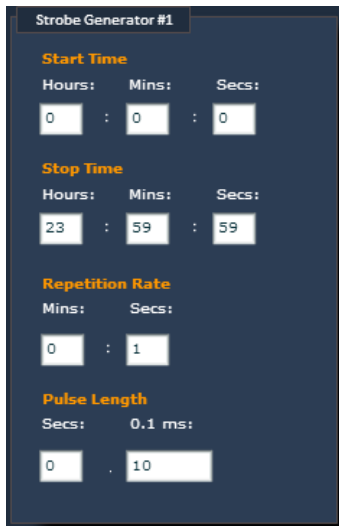

The following parameters can be set:

- <Start Time> HH:MM:SS
- <Stop Time> HH:MM:SS
- <Repetition Rate> MM:SS
- <Pulse Length> SS.ssss

The system generates a sequence of pulses of <Pulse Length> length and repeating every <Repetition Rate> starting at <Start Time> and stopping at <Stop Time>.

Please note that the <Start Time> is always synchronous to the internal PPS (eventually disciplined via an external source).

Clock Generation

The device is able to generate two distinct programmable square wave clocks by dividing two different sources with integer dividers:

- 10 MHz
- 16.384 MHz

Please note that the rising edge of the resulting clock is synchronous to the internal PPS, if the frequency is integer.



Board Bring-Up

First installation

- GPS: eventually connect the GPS antenna cable to its connector GPS ANTENNA on the back
- IRIG-B: eventually connect the IRIG-B input to an IRIG-B master (OPTICAL or ELECTRICAL)
- PTP: eventually connect an Ethernet cable to the port/s on the back (it's required that the network is IEEE 1588 compliant for best operation)
- Connect the ETS-EVO to the power grid

Check-up

At the first start is a good idea to verify the correct operation of the apparatus.

For default factory settings the device IP address is **192.168.200.2** for the lower interface and **10.0.0.1** for the upper one.

To eventually discover the IP address in use, if different, is possible to use the **Autodiscovery** utility downloadable from the Digital Instruments website³, or to connect to the device via serial console and verify the ip address with the command **ifconfig** (eth0 is the lower network interface, eth1 the upper one).

Connect to the apparatus using a standard Web browser to `http:// <apparatus_ip>`

The default credentials are:

admin (read and write)	→	admin / admin
guest (read only)	→	guest / guest

From here, it's possible to check:

- Presence of the GPS antenna
In *GPS* tab of *Main Panel*, the *Antenna* LED should be green and, after a few minutes from switch on, even the *PPS Status* LED
- Presence of the IRIG-B signal and correct date and time
Can be checked in the IRIG-B tab of the *Main Panel*
- Presence of a master PTP
In the PTP tab of the *Main Panel*, the *State* variable should indicate *Slave*

³ <ftp://digiguest:guestd@www.digital-instruments.it/AutoDiscovery.zip>

Appendix A: Quality Factor

General Review

This appendix is intended to illustrate the meaning and motivation of the introduction of the Quality Factor within the Digital Instruments equipments.

Although the installation of a GPS device is relatively easy, it can hide certain issues that in some cases it can affect the proper functioning.

It is therefore expected to monitoring certain operating parameters so as to make immediate validation of a Circuit or finding the source of any problems.

GPS antenna positioning

GPS antenna should be positioned on a tower or on a roof with a good view of the GPS satellite constellation.

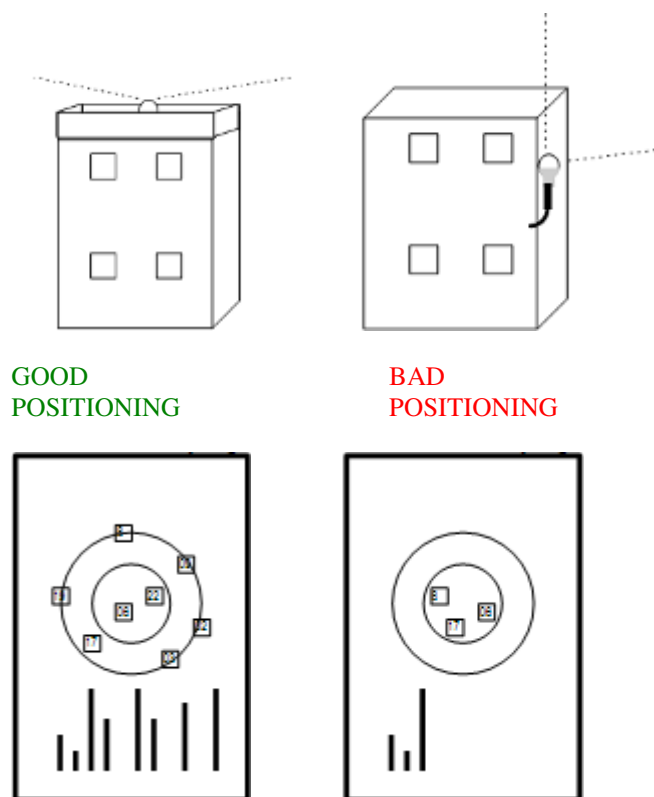

If not, the algorithm of regulation may not behave optimally and *short term stability* of the PPS and 10 MHz references it could be invalidated.

It's possible to evaluate the goodness of the positioning of the antenna in some ways:

1. checking the **power of received signal** from each satellite from the *Polar Plot*
2. checking and verifying that the **Quality Factor** is acceptable (typically > 25)
3. checking that the PPS generated by the radio (**PPS Status**) is valid (green LED)

Se così non fosse l'algoritmo di disciplinamento potrebbe non comportarsi in maniera ottimale e la *short term stability* dei riferimenti PPS e 10 MHz ne potrebbe venire inficiata.

It's possible get an idea of potential obstacles that limit the visibility of the GPS constellation to the radio observing the polar graph of satellites after a few hours of persistence.

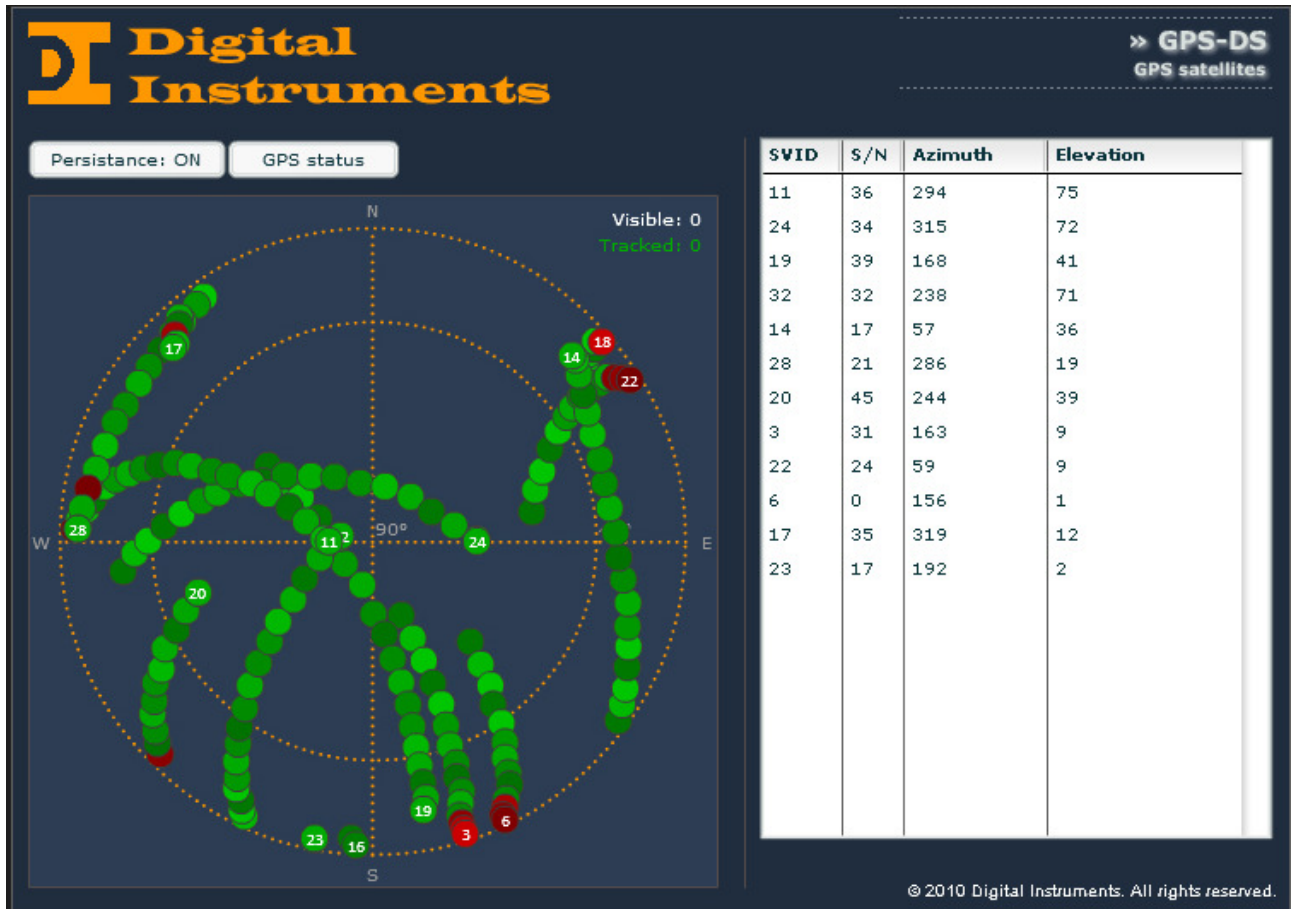

Quality Factor

Quality Factor is the operating parameter that indicates the quality of the GPS signal received by the antenna. It is considered an acceptable value if > 25 . If the Q.F. is lower, it is possible that there are problems with the GPS signal reception and this involves a greater number of holdover and therefore a less precise synchronization.

The value of the Quality Factor is shown in *GPS* tab of *Main Panel* Page.

PPS Status: ■

PPS Sync: ■

Antenna: ■

Position: ■

Quality: ■ 28

Statistics

The device stores some useful statistical informations to evaluate the proper functioning over time:

- Holdover Num** shows the number of times that the GPS radio has entered into holdover mode in response to a problem (under optimal conditions should be low)
- Holdover Max** shows the duration of the longer hold-over (under optimal conditions should be low)
- Quality Min** indicates the smallest GPS antenna quality factor recorded (under optimal conditions should be high)
- PPS Dist Max** indicates the maximum distance affected by the PPS generated by the GPS radio (under optimal conditions should be low)
- Pos Alarm Num** indicates the number of times that there was a wrong geo-positioning under optimal conditions should be low)



It's a good idea to reset the stats before a capture session, because some values may be spurious in the first phase of synchronization or acquisition of satellites by the GPS radio.

Automatic Site Survey



In certain situations it may be convenient activate the *Positioning Mode* of GPS radio in *Automatic Site Survey*. In this mode the radio privileges the accuracy of temporal information at the expense of that position (as long as the antenna is not moved), so as to preserve signal integrity PPS in limited visibility conditions or in the GPS constellation or in presence of potential sources of interference.



If there are problems or abnormalities during the first installation or after moving the unit in a distant geographic location, GPS radio can be reseted by deleting the almanac and positioning information that is saved by the appropriate entry in the GPS menu. Should be also necessary to reset the device in *Automatic Site Survey* mode, since the radio, after completing the survey - which takes about 3 hours - automatically returns to *Position Hold* mode.

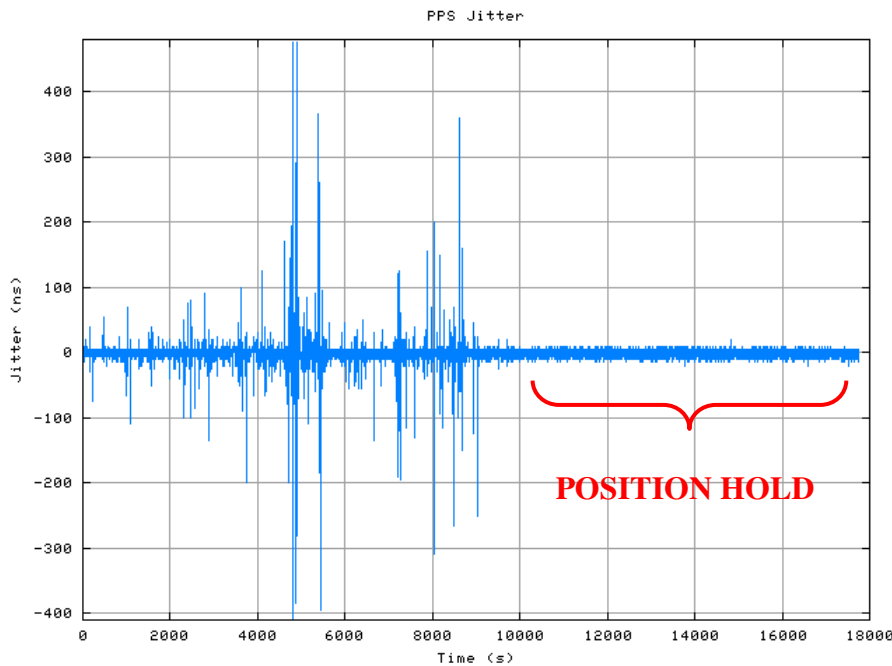

Appendix B: FAQ

D: Why is date and time not updating in the main web page?

R: You should check that the web browser is not caching pages. With Internet Explorer this can be done under Internet Options → General → Settings (in the Temporary Internet Files field) by checking that the setting "Check for newer versions of stored pages" is done "Every visit to the page".

The same approach can be used for the other web browsers as well (Mozilla Firefox, Google Chrome, Safari, ...)

D: The web interface is not correctly being shown.

R: It may be needed to update the Adobe Flash Player plug-in from the following internet web site <http://get.adobe.com/it/flashplayer/> (on-line installation) or from the following link

http://kb2.adobe.com/cps/191/tn_19166.html#main Install in a firewall proxy server environment (off-line installation)

D: How can I get additional info about the NTP service status?

R: The main informations are shown on the *Sources Config Panel* web page. Furthermore the device replies to *ntpq* queries. If it is not feasible to install it on a different PC it is still possible to connect to the device via telnet and issue the following commands:

```
cd /var/tmp
./ntpq 127.0.0.1
```

Is now possible to query the NTP service with the commands shown in the following page:

<http://www.eecis.udel.edu/~mills/ntp/html/ntpq.html>

The most used commands are *peers*, *as e rv &n* (where *n* is the source number)

D: How can I configure the device as NTP client?

R: The syntax to be used is described at the following page:

<http://www.eecis.udel.edu/~mills/ntp/html/confopt.html#server>

For factory settings the device ships configured as NTP server. In order to configure it as a client is sufficient to add the following directive in the NTP configuration panel:

```
server x.x.x.x minpoll 4 maxpoll 4 prefer
```

D: How can I synchronize the device with the Win32Time service?

R: A few intermediate steps are needed. Since Windows synchronization is quite loose it may be discarded by the NTP client.

1. From the windows console digit:
`w32tm /config /manualpeerlist:,0x8 /syncfromflags:MANUAL`
2. Set the following registry key to 0 (via *regedit*)
`HKLM\SYSTEM\CurrentControlSet\Services\W32Time\Config\LocalClockDispersion`
3. Restart the *Windows Time Service*
4. Add the following line in the client NTP configuration file of the ETS-EVO
`tinker panic 0 stepout 256`
`tos maxdist 2.5`

D: How can I test the NTP server quality?

R: A simple test is to configure an external client to listen to both the ETS-EVO and a server from the Internet. Comparing the offsets with the *ntpq* program it is possible to get an idea about the precision of the synchronization.

Appendix C: Changelog

Release 3.1 (february 2012)

- First version with complete MMU support
- Added support for serial protocols

Release 3.2 (february 2012)

- Improved network management

Release 3.3 (march 2012)

- Added info on NTP service status
- Handle two NICs configured on the same subnet

Release 3.4 (march 2012)

- Added info on the NTP synchronization status
- Added tooltips over the TLS and TLC leds in the web interface
- Added possibility to save and restore device configuration
- The SYNC led on the front panel indicates the status of the NTP synchronization, too

Release 3.5 (may 2012)

- Reverted the numbering of TLS and TLC to reflect what stated on the manual

Release 3.6 (may 2012)

- Fixed reboot in case of SNMP trap sending
- Added some NTP conf directives

Release 3.7 (may 2012)

- Added source IP in sent traps
- Added ntp sync event

Release 3.8 (june 2012)

- Added support for ABB SPA Time String

Release 3.9 (july 2012)

- Added support for NMEA string
- 30 minutes interval timezone supported
- IRIG-B input considered in local time

Release 4.0 (july 2012)

- Added minimal support for PTP unicast

Release 4.1 (july 2012)

- Added PTP custom parameters

Release 4.2 (august 2012)

- Added disciplining parameters in PTP Announce Message
- Auto-recognition of the IRIG-B input
- IRIG-B robustness increased

Release 4.3 (august 2012)

- Added support for PTPv2 unicast through signalling messages

Release 4.4 (september 2012)

- SyncE management simplified

Release 4.5 (september 2012)

- Added pulse generation support

Release 4.6 (october 2012)

- Added clock generation support

Release 4.7 (october 2012)

- Added handling of the ESMC packets for the SyncE

Assistance

For support requests please download the form from the website:

<http://www.digital-instruments.it/ita/assistenza.php>

Compile it in its entirety by specifying as precisely as possible and giving as many details as possible about the type of fault detected.

You can then send the form to **riparazioni@digital-instruments.com**, via fax to **+39.02.66506103**, or enter it directly into the box when sending goods for repair.

You can also contact us at +39.02.66506250 Monday to Friday from 9 to 13 and from 14 to 17 (GMT+1 Time).

Technical Data

Frequency Reference

Signal	10 MHz sine wave (Square wave optional), 2.048 MHz optional
Spectral Purity	-70 dBc (harmonic) -75 dBc (non-harmonic)
Phase noise	-130 dBc at 1kHz
Output	1
Output level	13 dBm
Output impedance	50 Ω
Output connector	BNC
Stability	1e-12 daily average (OCXO locked to GPS on SA) 1e-10 daily average (OCXO free run)

Time Reference

Signal	1 PPS, 100 μ s Duty, Rising Edge
Output	1
Output level	TTL 5 Vpp, Square wave
Output impedance	50 Ω
Output connector	BNC

GPS Section

Receiver	12 Channels L1 1575.42 MHz
Tracking	Correlation on 12 satellites
PPS accuracy	< 50 ns on SA
Antenna connector	TNC
Collection time	< 4 min

PTP Section

Network connection	N° 2 Ethernet 10/100 interfaces
Protocol	IEEE 1588-2008 (PTPv2) – PTPv1 optional
Role	Grandmaster clock source (GPS) or slave
Time stamping	Hardware
Precision	< 1 μ s
Options	Multicast, Unicast, E2E, P2P, UDP/IPv4

NTP Section

Protocol	NTP version 4
Role	Grandmaster clock source (GPS) or relay
Time stamping	Software
Stratum	1 or 2
Precision	< 10 ms

Generated Time Codes

IRIG	User defined / IRIG-B DCLS
Connectors	Electrical: BNC; Optical: ST

Signaling

Network connection	N° 2 Ethernet 10/100 interfaces, TCP/IP protocol
Signaling	N° 5 led on front panel
Serial Connection	RS-232 connector DB9 Male +/- 15 kV (ESD)
Remote signalling	7 Dry contact on Weidmuller connector with 3.5 mm step
Remote controllers	4 Dry contact on Weidmuller connector with 3.5 mm step

Supply

Input	N° 2 independent supply
Network	95 Vac < > 240 Vac Plug IEC320 integrated, filter EMI/RFI
Battery	36 Vdc < > 75 Vdc

Certifications

CE and GOST-R

Sizes

Width	1 Unit 19"
Depth	300 mm without connectors
Weight	1.5 Kg

Accessories

1 x GPS Antenna
1 x 30 m Belden PRG 7 Cable
2 m Cordon for network supply
2 m Cordon for battery supply
Handbook in English/Italian